

**STAGE 1**

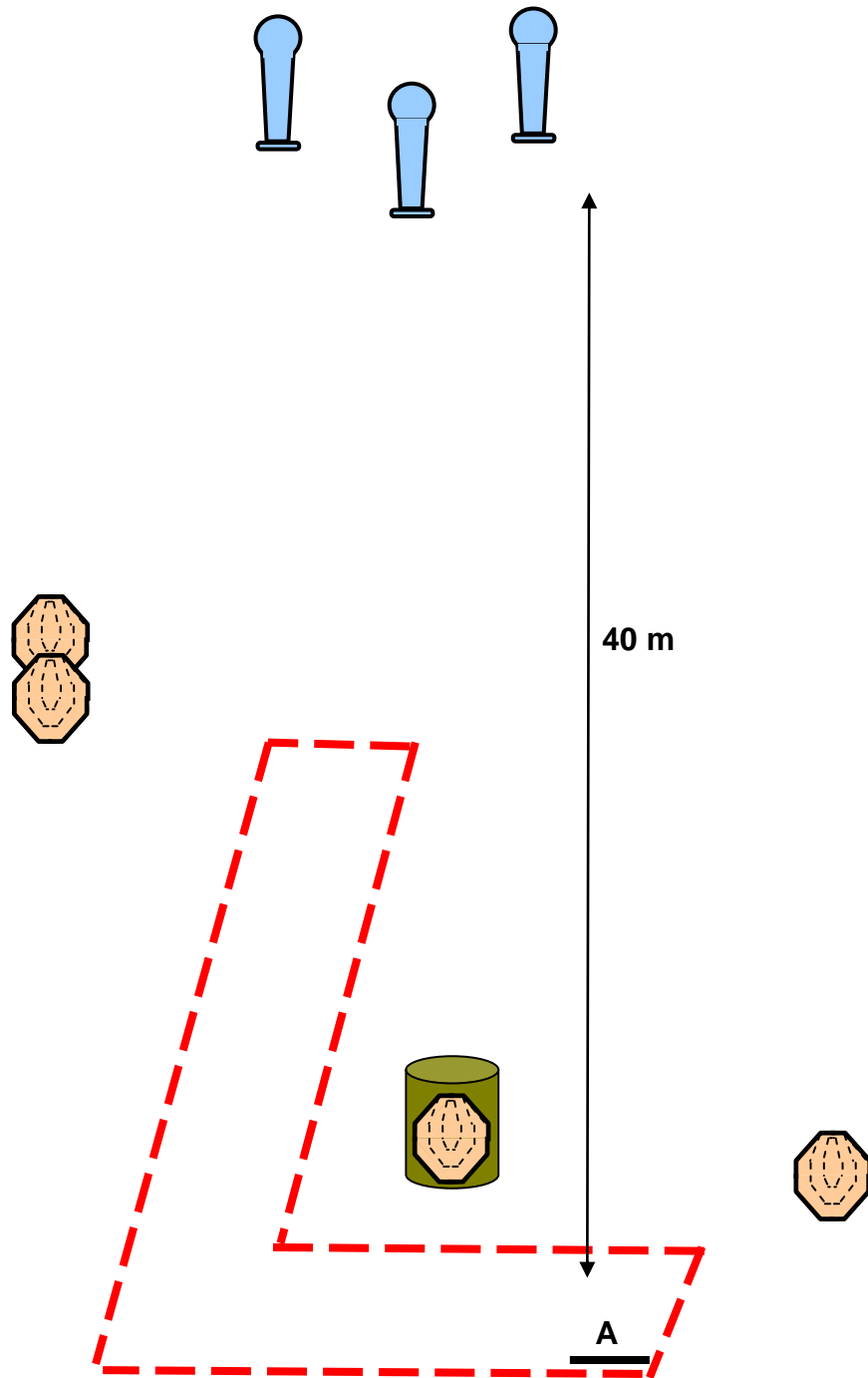

SIAULIAI OPEN 2019

**STAGE: 1**

COURSE: Short Course.

TARGETS: IPSC Targets 4, IPSC Poppers 3.

ROUNDS TO BE SCORED: 11.

MAXIMUM POINTS: 55.

START POSITION: Standing at A, facing downrange.

TIME START: Audible signal.

PROCEDURE: After start signal engage all targets

## STAGE 2

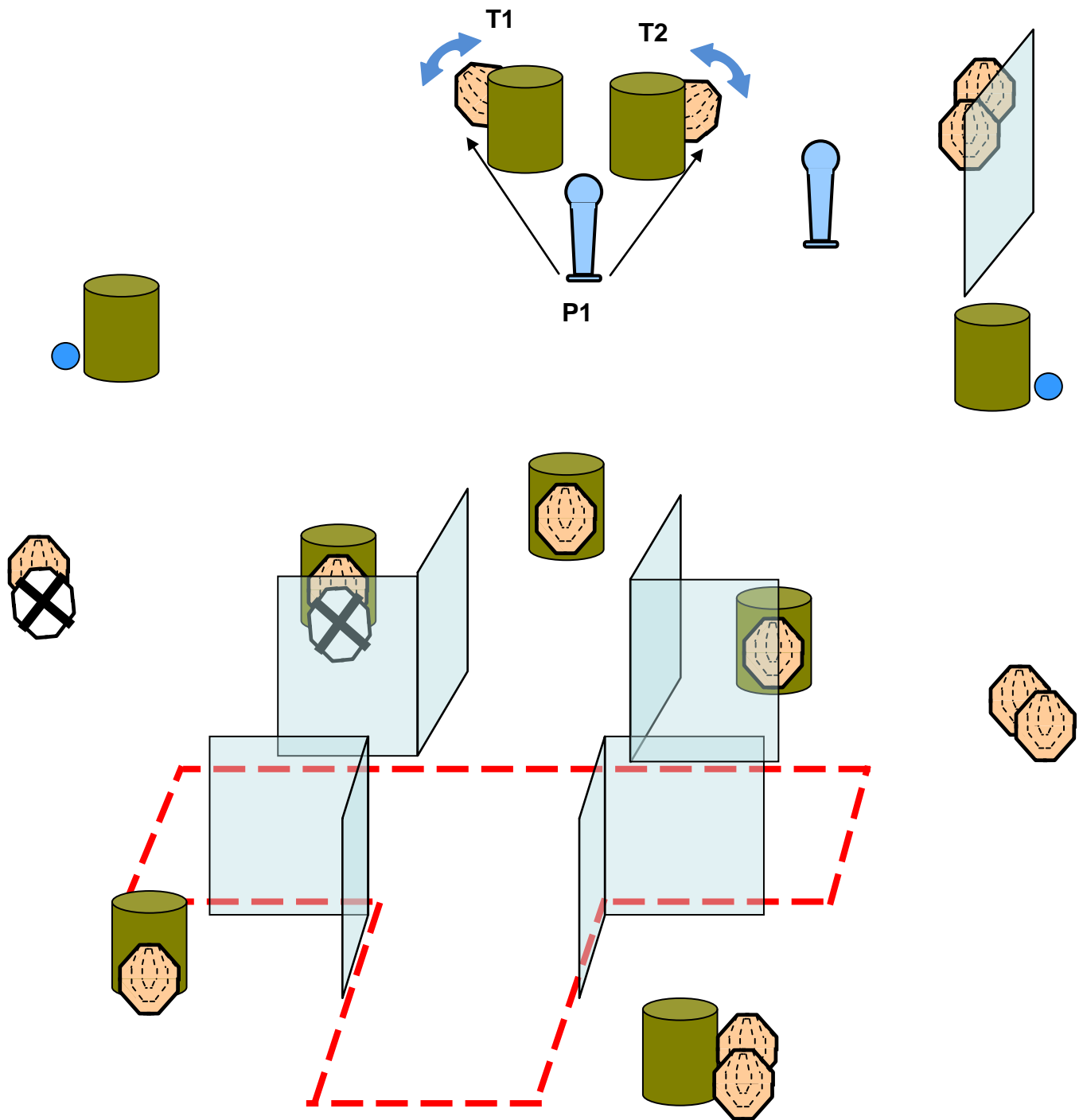

SIAULIAI OPEN 2019

### STAGE: 2

COURSE: Long Course.

TARGETS: IPSC Targets 13, IPSC Poppers 2, IPSC Plates 2, No-Shoots 2.

ROUNDS TO BE SCORED: 30.

MAXIMUM POINTS: 150.

START POSITION: Standing anywhere in the designated area, facing downrange.

TIME START: Audible signal.

PROCEDURE: After start signal engage all targets.

SPECIAL EQUIPMENT: Popper P1 activates swingers T1/T2, which stay visible at rest.

### STAGE 3

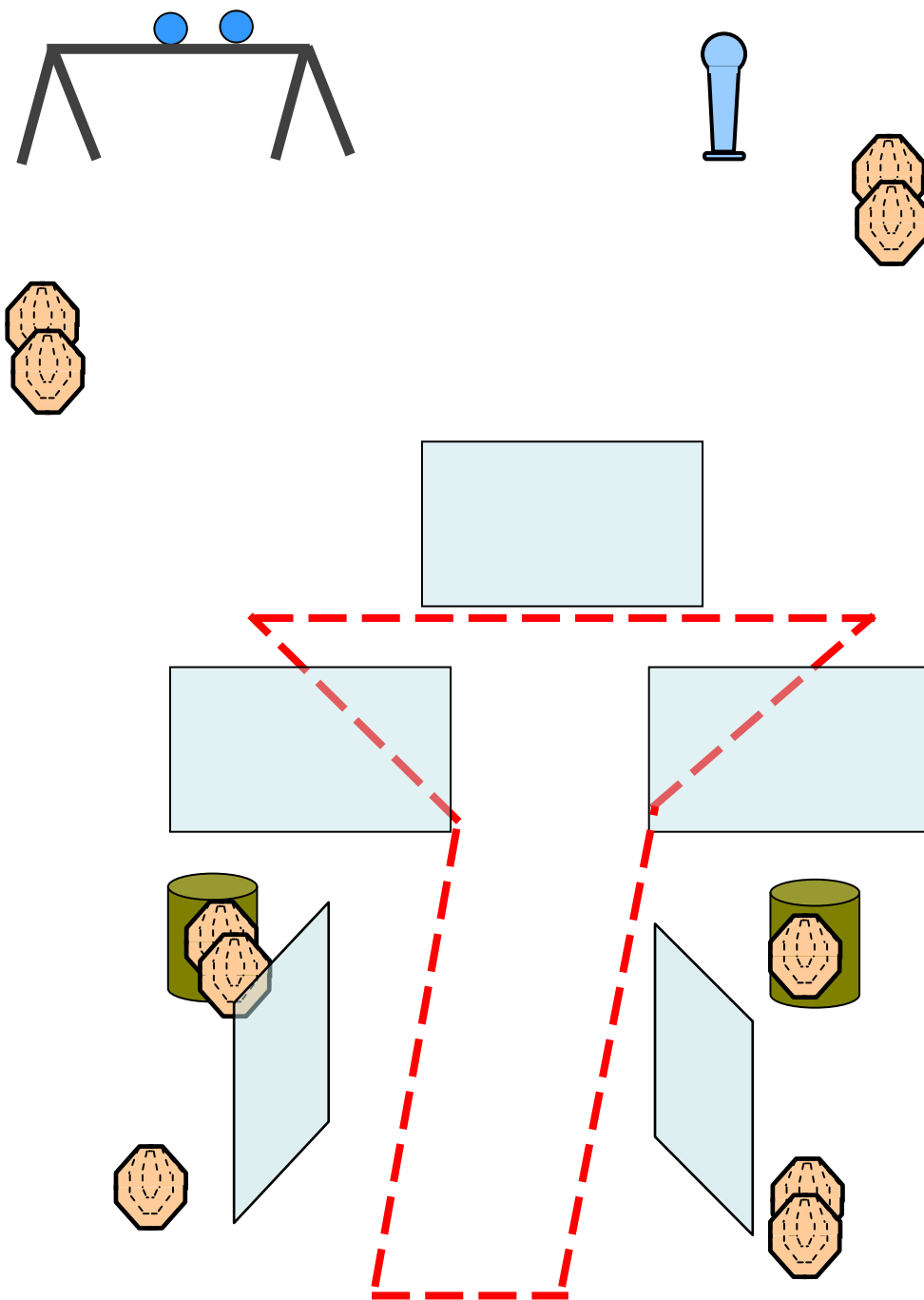

SIAULIAI OPEN 2019

#### STAGE: 3

COURSE: Medium Course.

TARGETS: IPSC Targets 10, IPSC Popper 1, IPSC Plates 2.

ROUNDS TO BE SCORED: 23.

MAXIMUM POINTS: 115.

START POSITION: Standing anywhere in the designated area, facing downrange.

TIME START: Audible signal.

PROCEDURE: After start signal engage all targets.

## STAGE 4

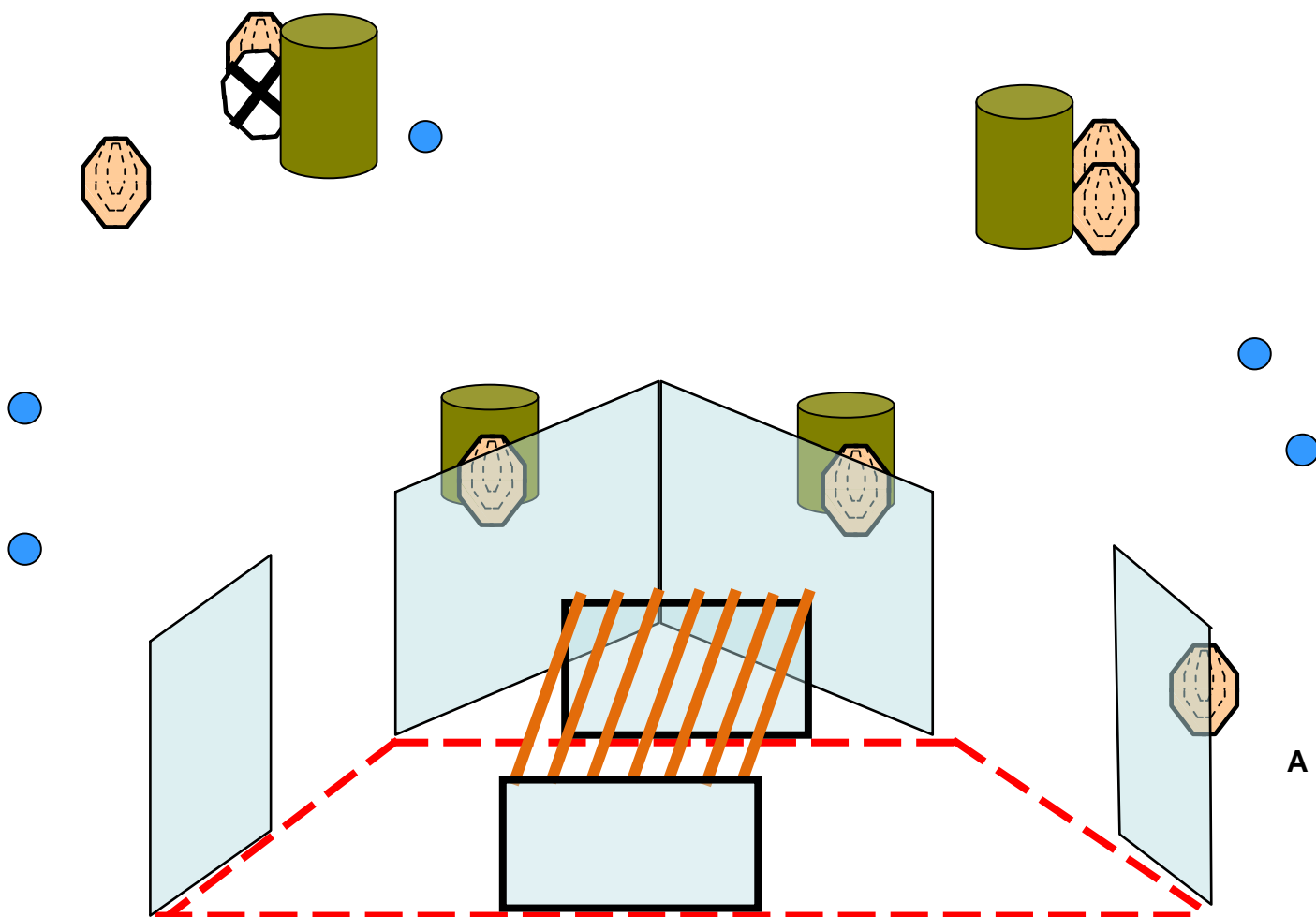

SIAULIAI OPEN 2019

### STAGE: 4

COURSE: Medium Course.

TARGETS: IPSC Targets 7, IPSC Plates 5, No-Shoots 1.

ROUNDS TO BE SCORED: 19.

MAXIMUM POINTS: 95.

START POSITION: Standing anywhere in the designated area, facing downrange.

TIME START: Audible signal.

PROCEDURE: After start signal engage all targets.

SPECIAL EQUIPMENT: Cooper tunnel.

# STAGE 5

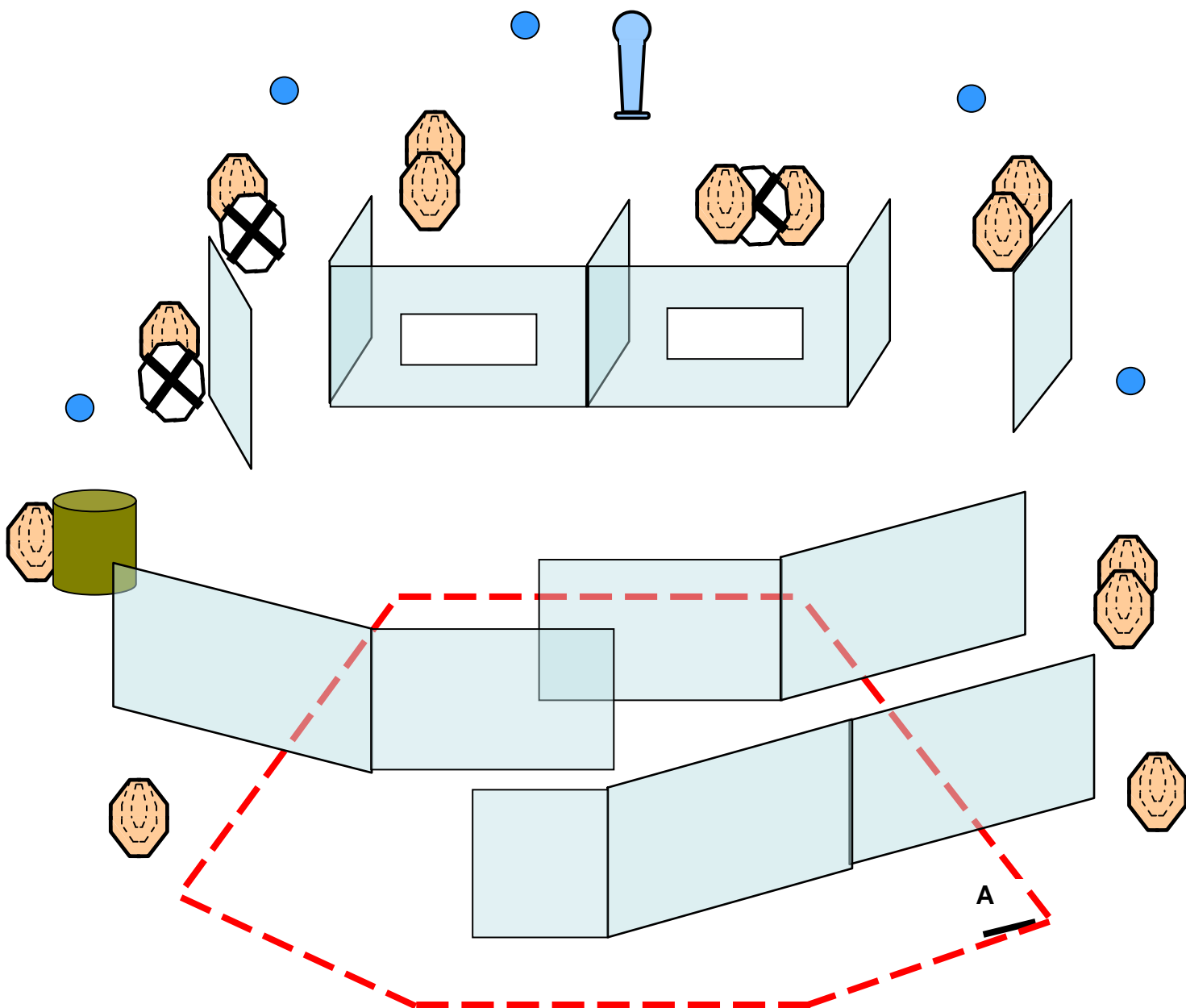

SIAULIAI OPEN 2019

## STAGE: 5

COURSE: Long Course.

TARGETS: IPSC Targets 13, IPSC Poppers 1, IPSC Plates 5, No-Shoots 3.

ROUNDS TO BE SCORED: 32.

MAXIMUM POINTS: 160.

START POSITION: Standing at A, facing downrange.

TIME START: Audible signal.

PROCEDURE: After start signal engage all targets.

**STAGE 6**

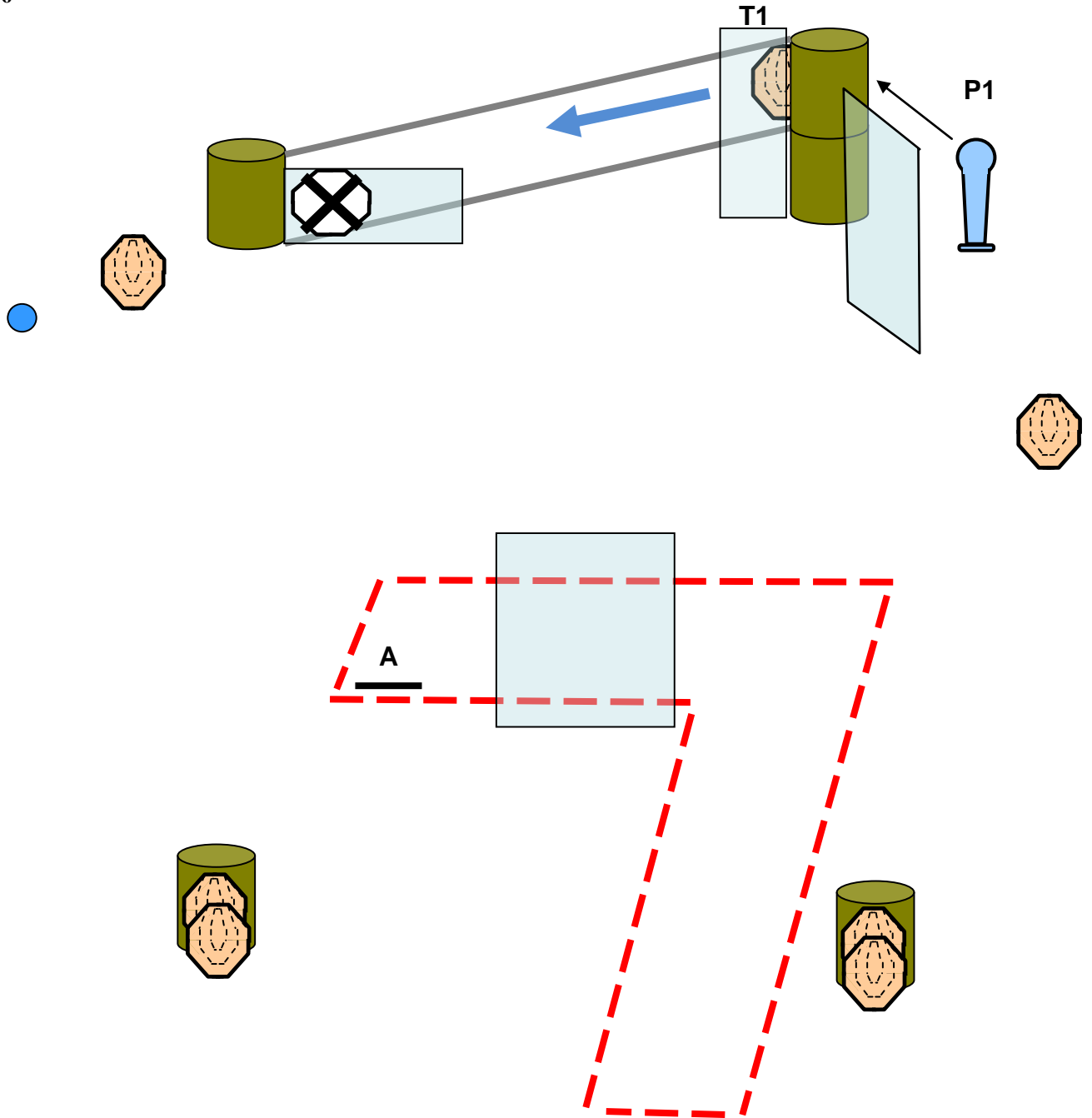

SIAULIAI OPEN 2019

**STAGE: 6**

COURSE: Medium Course.

TARGETS: IPSC Targets 7, IPSC Popper 1, IPSC Plate 1, No-Shoot 1.

ROUNDS TO BE SCORED: 16.

MAXIMUM POINTS: 80.

START POSITION: Standing at A, facing downrange.

TIME START: Audible signal.

PROCEDURE: After start signal engage all targets.

SPECIAL EQUIPMENT: Popper P1 activates moving target T1, which stays visible at rest.

## STAGE 7

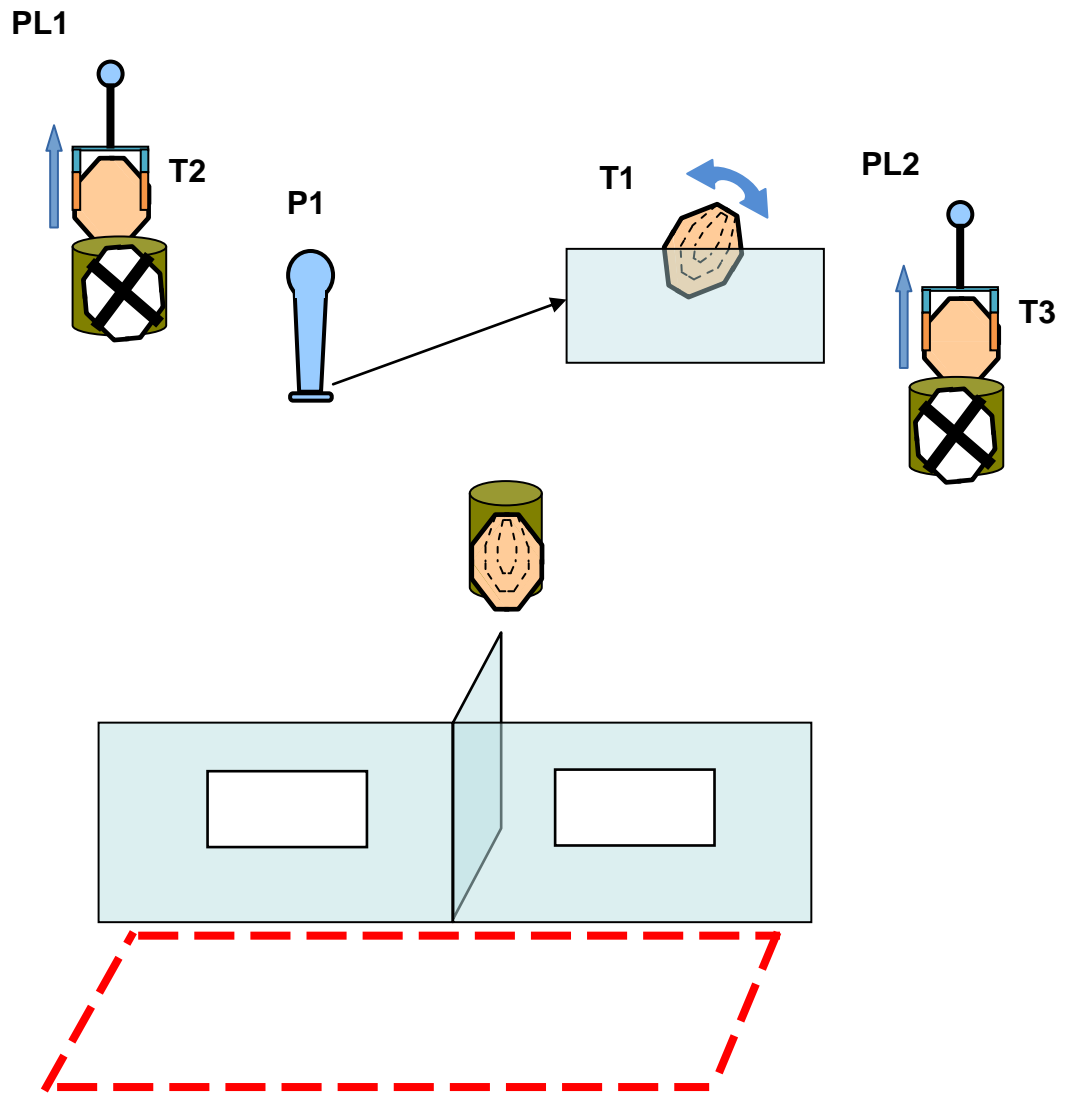

SIAULIAI OPEN 2019

### STAGE: 7

COURSE: Short Course.

TARGETS: IPSC Targets 4, IPSC Popper 1, IPSC Plates 2, No-Shoots 2.

ROUNDS TO BE SCORED: 11.

MAXIMUM POINTS: 55.

START POSITION: Standing anywhere in the designated area, facing downrange.

TIME START: Audible signal.

PROCEDURE: After start signal engage all targets.

SPECIAL EQUIPMENT: Popper P1 activates swinger T1, which stays visible at rest. Plates PL1/PL2 activates flip-up targets T2/T3.

## STAGE 8

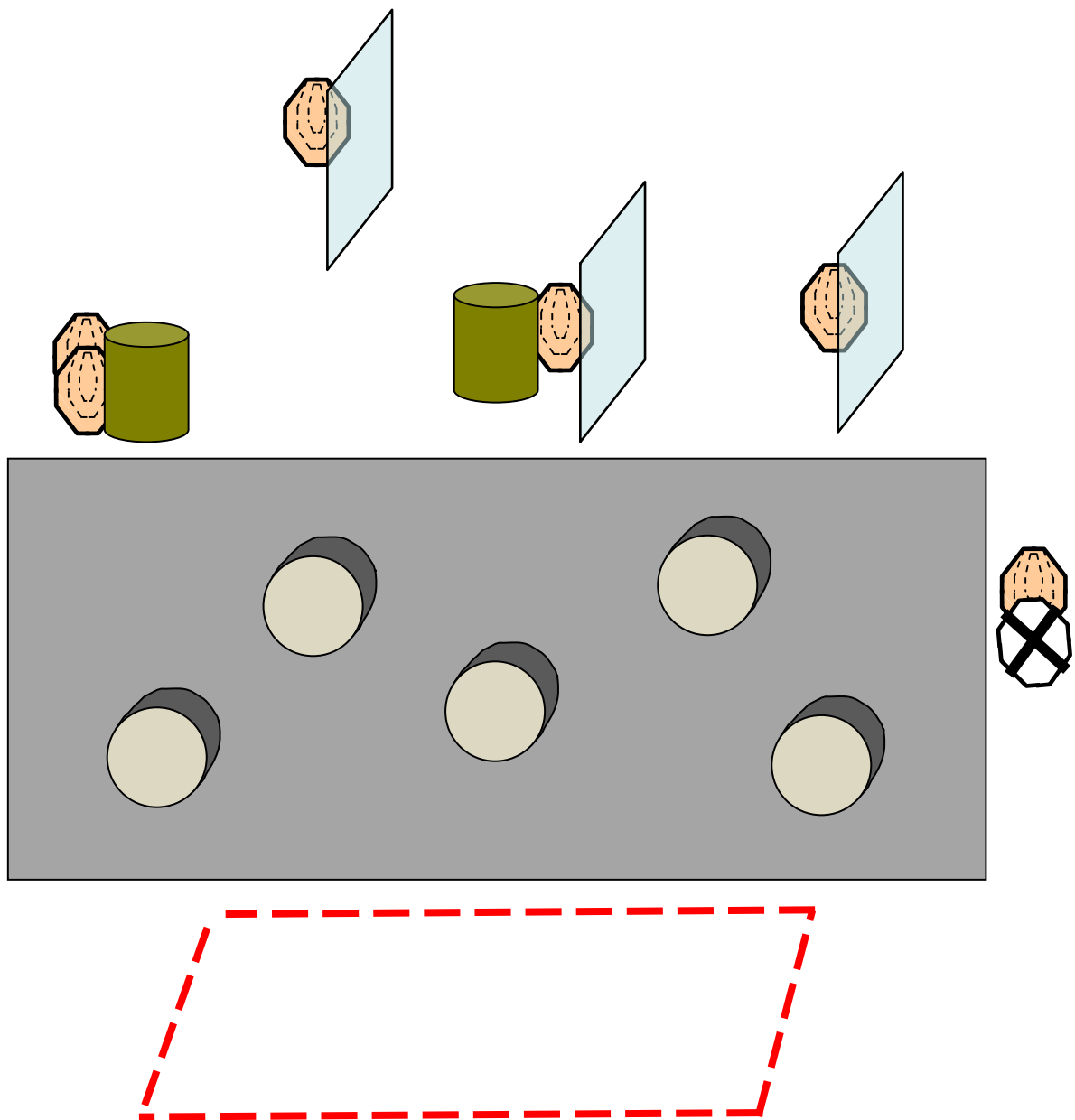

SIAULIAI OPEN 2019

### STAGE: 8

COURSE: Short Course.

TARGETS: IPSC Targets 6, No-Shoots 1.

ROUNDS TO BE SCORED: 12

MAXIMUM POINTS: 60.

START POSITION: Standing anywhere in the designated area, facing downrange.

TIME START: Audible signal.

PROCEDURE: After start signal engage all targets.

(NOTE: All targets are visible only through pipes.)



## STAGE 9

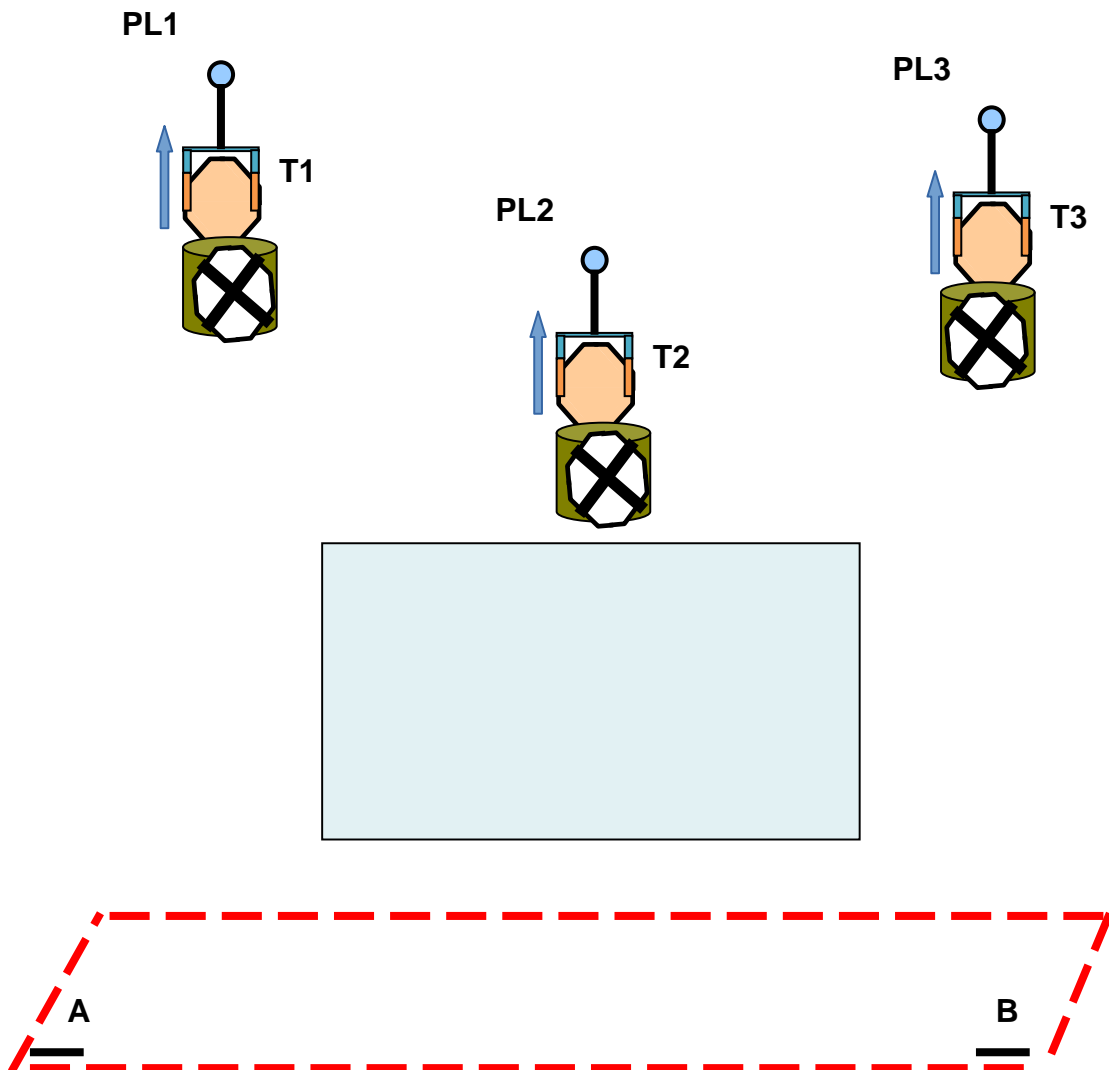

SIAULIAI OPEN 2019

### STAGE: 9

COURSE: Short Course.

TARGETS: IPSC Targets 3, IPSC Plates 3 No-Shoots 3.

ROUNDS TO BE SCORED: 9.

MAXIMUM POINTS: 45.

START POSITION: Standing at A or B, facing downrange.

TIME START: Audible signal.

PROCEDURE: After start signal engage all targets using **STRONG HAND ONLY**.

SPECIAL EQUIPMENT: Plates PL1/PL2/PL3 activates flip-up targets T1/T2/T3.

**STAGE 10**

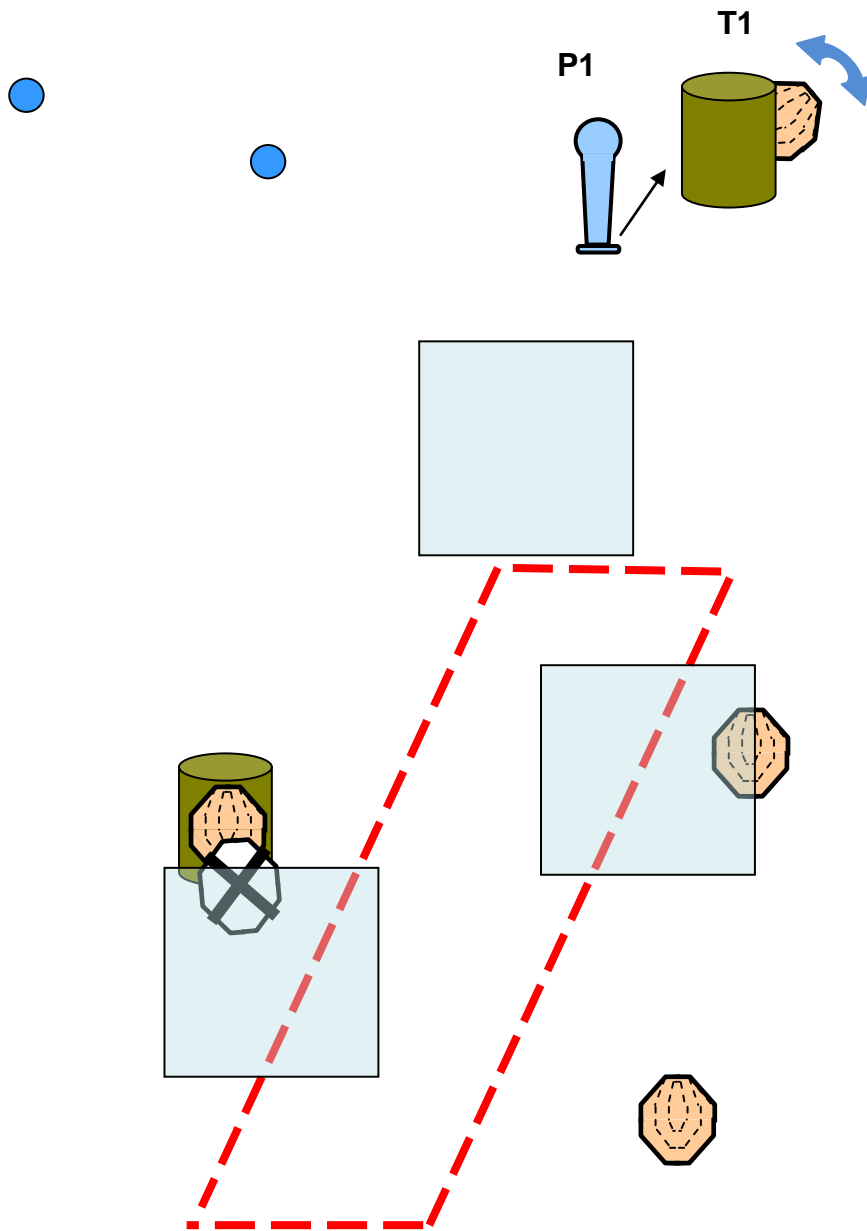

SIAULIAI OPEN 2019

**STAGE: 10**

COURSE: Short Course.

TARGETS: IPSC Targets 4, IPSC Poppers 1, IPSC Plates 2, No-Shoots 1.

ROUNDS TO BE SCORED: 11.

MAXIMUM POINTS: 55.

START POSITION: Standing anywhere in the designated area, facing downrange.

TIME START: Audible signal.

PROCEDURE: After start signal engage all targets.

SPECIAL EQUIPMENT: Popper P1 activates swinger T1, which stays visible at rest.

# STAGE 11

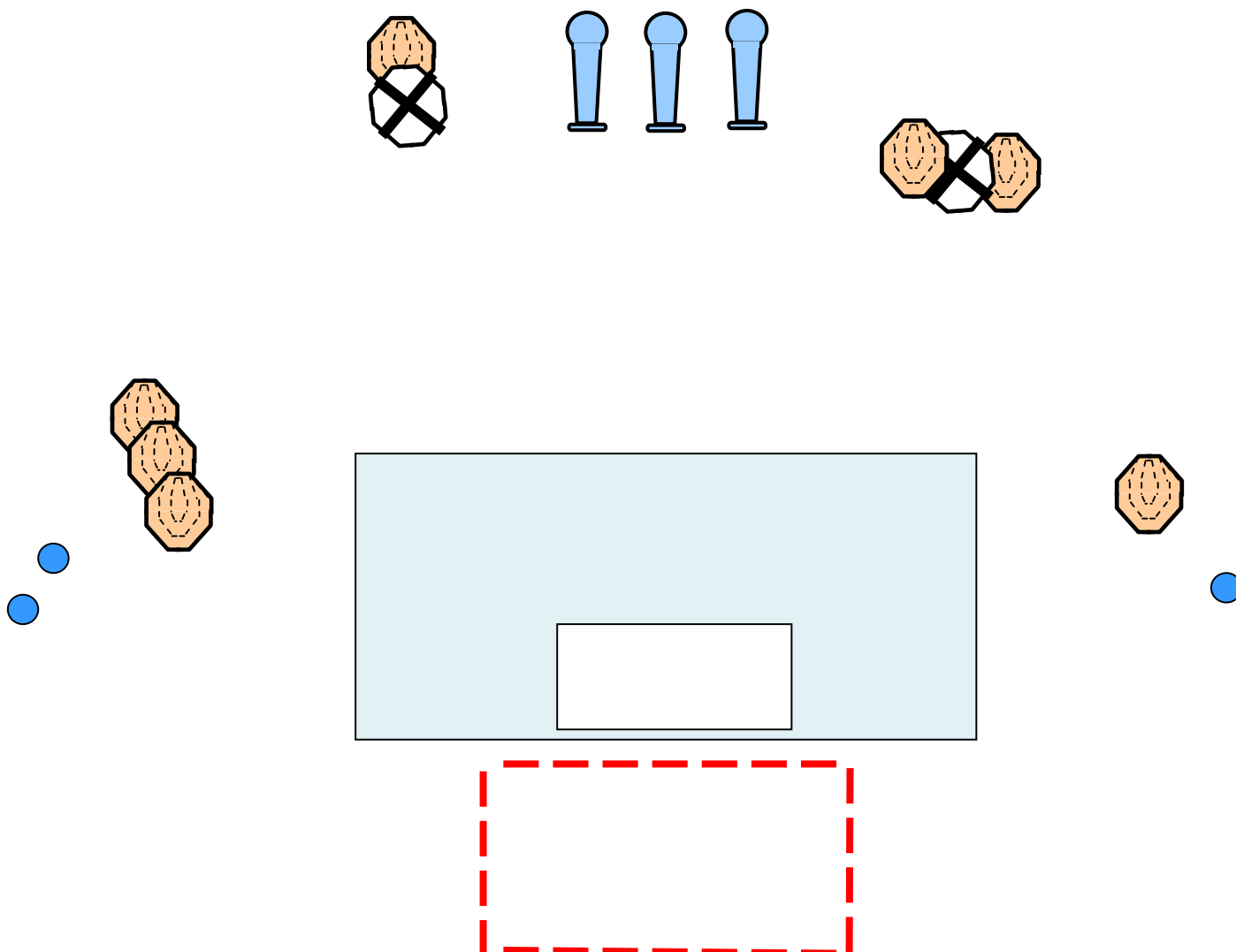

SIAULIAI OPEN 2019

## STAGE: 11

COURSE: Medium Course.

TARGETS: IPSC Targets 7, IPSC Poppers 3, IPSC Plates 3, No-Shoots 2.

ROUNDS TO BE SCORED: 20.

MAXIMUM POINTS: 100.

START POSITION: Standing anywhere in the designated area, facing downrange.

TIME START: Audible signal.

PROCEDURE: After start signal engage all targets.

# STAGE 12

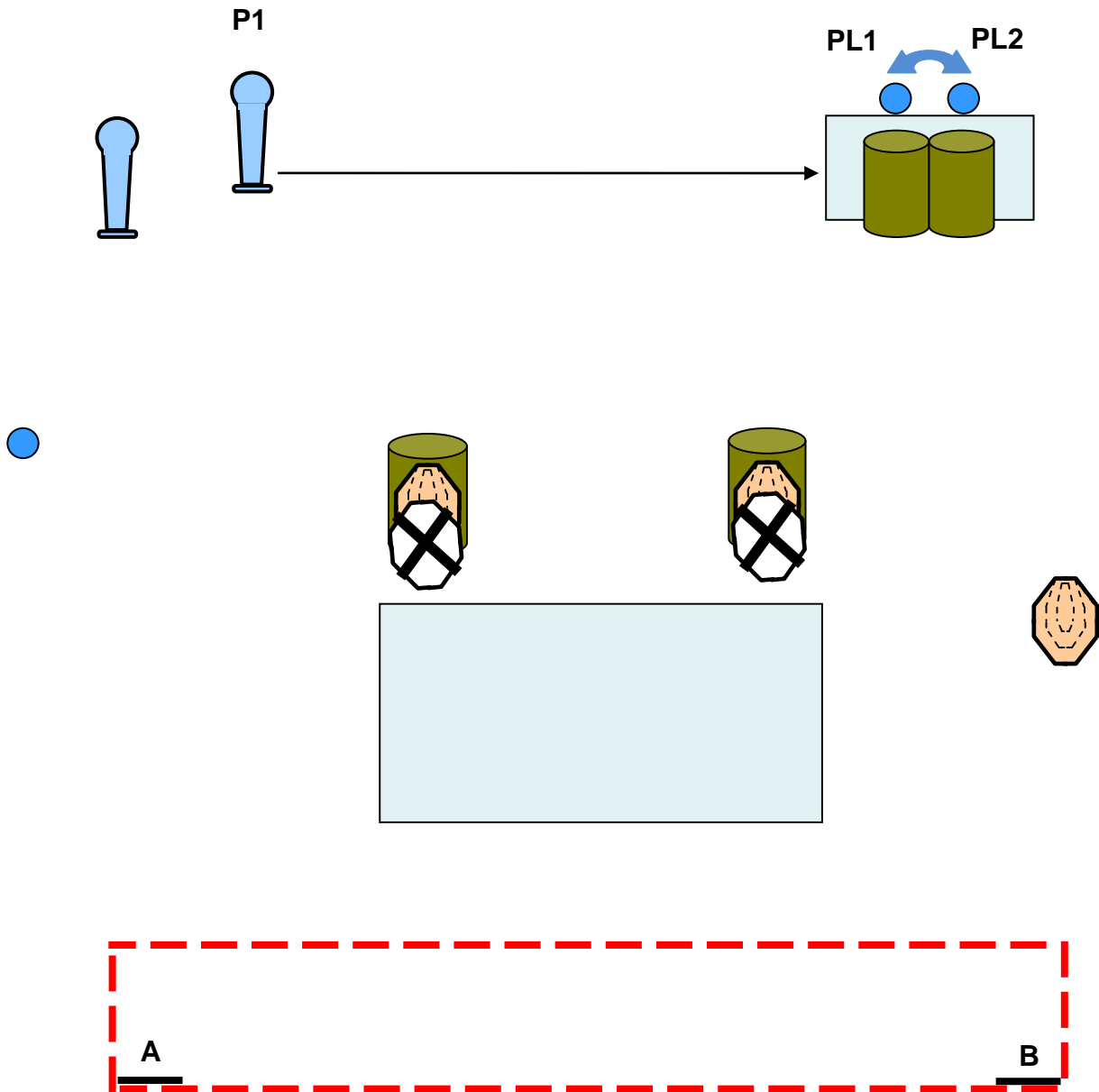

SIAULIAI OPEN 2019

## STAGE: 12

COURSE: Short Course.

TARGETS: IPSC Targets 3, IPSC Poppers 2 IPSC Plates 3, No-Shoots 2.

ROUNDS TO BE SCORED: 11.

MAXIMUM POINTS: 55.

START POSITION: Standing at A or B, facing downrange.

TIME START: Audible signal.

PROCEDURE: After start signal engage all targets.

SPECIAL EQUIPMENT: Popper P1 activates swinging plates PL1/PL2, which stay visible at rest.